

CONSIDERATIONS CONCERNING THE EVALUATION OF TOWING FORCES FOR ROAD TRANSPORTATION OF AGABARITICAL MECHANICAL EQUIPMENT

RADU IATAN*¹, MIHAI STATESCU², ION DURBACA¹,
GEORGIANA LUMINITA ENACHESCU¹

¹*Department for Industrial Process Equipment, Polytechnic University of Bucharest, Splaiul Independenței 313, Sector 6, Bucharest, 060042, Romania*

²*SPEC Engineering and Construction SRL, Bucharest, Romania*

Abstract. The full safety of operating industrial mechanical equipment, in particular the over-sized ones, with a complex structure, is ensured by compliance with all necessary requirements, starting with design, fabrication, transportation from the supplier to the recipient and operation within the working parameters. The present article that is continuing the analysis of transportation stages of over-sized and heavy equipment, as can be seen from the attached bibliography, takes into consideration the evaluation of the towing forces, in the case of two distant platforms. The masses of the transported components, the characteristics of the roadways, as well as the character of the movement and the influence of the wind loads are considered.

Keywords: mechanical equipment, over-sized equipment, roadways, dynamics of movement

1. INTRODUCTION

The need to increase the quantity of finished products, together with the increase of the processing of raw materials and of higher use of the secondary products, has also led to the development of equipment with increasing size, of complex construction and to work at higher parameters [1, 2]. The final functional safety of mechanical equipment is ensured by the quality of all the stages ranging from design to commissioning and operation. Of these stages stands out, the transport from the manufacturer to the end user, in essence the one of large mechanical equipment and, at the same time, with large masses, of recognized importance for the economy [3, 4]. The lifting of the equipment with the mentioned specifications, for the placement on the transportation platforms, their secure anchoring, as well as the unloading at the site on the foundations implies the use of suitable constructive elements, with well-defined bearing capacity [2, 5-10]. The global analysis of an oversized transport considers not only the legal and constructive and human safety aspects, but also the economic, social and environmental ones. The problem of road transport for the equipment with exceeded tonnage and / or oversized [11-31] has determined a number of companies from abroad to specialize in designing and realizing cost-effective systems for transport, of high capacity, following a varied program of manufacture of standard sizes. In order to achieve rational transports, satisfying the desired requirements, these companies introduced in the concept of trailers and semi-trailers manufacturing (used as platforms for loading and transporting machines) the notion of "modulation". In this sense, it is possible to combine several transport elements called "modules" and some typical annexes, compatible for the equipment being moved [32]. *Trailers* can be made from modules with 2 to 10 lines, longitudinally or transversely

* Corresponding author, email: iatan.radu@gmail.com

coupled [2, 32]. Among their *advantages* are: a) the possibility of remotely carrying out the necessary orders; b) the weight of the structure is small (compared to the mass of the load it is up to 20 times smaller); c) allow easy adaptation, taking into account the mass, the shape, the driving conditions, the permissible axle or wheel load, the road slope etc.; d) reduced time for realizing possible combinations in width and length; e) quick connection of elastic, hydraulic and pneumatic systems between modules; f) quick mounting and dismantling of the end cross member. The *advantages of semi-trailers* include [2, 32]: a) superior maneuverability; b) easy joining in curves with smaller medium radii; c) the possibility of easier and safer coupling with the tractor; d) going back easier; e) possibility of transporting long and bulky cargoes, due to using a larger surface area of the platform; f) reducing the length of the train (convoy); g) due to the better connections between the towing mechanisms an improvement of the traffic safety is achieved, for higher speeds of movement. There are also some *disadvantages*: a) the oscillations of the tractor, especially those with respect to the transverse axis are unpleasant for driving, due to the short wheelbase of the tractor with saddle; b) when climbing the ramps, due to the uneven distribution of the mass / weight of the transported equipment – platform, on the rear axles, the grip is reduced.

It should not be overlooked that road transport is more easily adapted to market demand, as opposed to rail, where inertia is higher [32]. The general cost of transport should include some additional works to divert the existing roads, widen road sections, build terraces, strengthen roads and bridges, etc., necessary to ensure the safety of transport equipment and to protect their integrity [2]. After establishing the mode of transport, it is important to obtain, from the authorities, the necessary approvals for each individual case [11, 12].

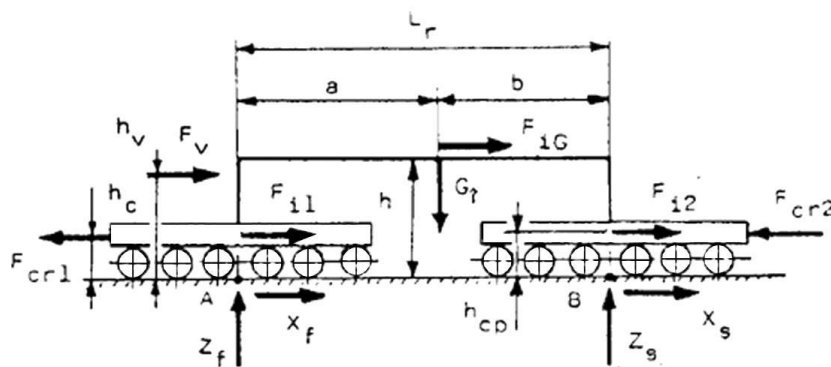

Fig. 1. Transport system with two distant trailers (sketch) [2].

Ensuring the constructive integrity of the transported equipment besides loading / unloading, respectively fixing / anchoring on the appropriate platforms, is defined by the transport mode. In this sense, the longitudinal stability of the platforms [34-41] and the transversal [42-48], on relatively horizontal paths, with straight line motion, must be evaluated and materialized. At the same time, the dynamics of towing vehicles must also be analyzed [49-59]. A necessary evaluation is the one regarding the intensity of the towing forces in the case of systems for moving in a straight line or in curves, the equipment positioned on two distant platforms, as presented in the case of this article.

2. SYSTEMS WITH TWO MODULES APART

2.1. Movement in a straight line

Case 1. The transport system moves in a straight line, *in acceleration mode, on a horizontal road*. The articulated trailer is treated with two tractor units, one puller placed in front of the convoy, the other pushing behind the convoy (Figure 1). Making the sum of bending moments in relation to points A and B (Figure 1) it is obtained:

$$Z_f = \frac{G_i \cdot b + G_{pf} \cdot L_r - F_{iG} \cdot h - (F_{i1} + F_{i2}) \cdot h_{cp} + (F_{cr1} + F_{cr2}) \cdot h_c - F_v \cdot h_v}{L_r} \quad (1)$$

$$Z_s = \frac{G_i \cdot a + G_{p_s} \cdot L_r + F_{iG} \cdot h + (F_{i1} + F_{i2}) \cdot h_{cp} - (F_{cr1} + F_{cr2}) \cdot h_c + F_v \cdot h_v}{L_r} \quad (2)$$

where G_i is the weight of the load, N ; F_{iG} - the inertia force of the load, N ; F_{i1} , F_{i2} - the inertia forces of the transporting platform, N ; F_{iG} - the inertia force positioned in the center of gravity of the transported equipment, N ; F_{cr1} , F_{cr2} - the forces at the hooks of the two towing means coupled to the trailers, N ; G_{pf} , G_{ps} - the weight of the front and back modules, N ; F_v - wind resistance force, opposing the movement (when acting from behind is considered in the calculation with the minus sign), N ; L_r - the distance between the supports (placed at the middle of the platforms), m ; h - position of the center of mass of the load in relation to the surface of the road, m ; h_{cp} - the position of the center of mass of the transport modules relative to the road surface, m ; h_c - the distance from the towing hooks position and the road surface, m ; a, b - distances from the means of the platforms to the center of mass of the transported equipment, m ; h_v - the position of the concentrated action of the wind against the road surface, m .

Note: In equations (1) and (2) the wind force F_v it is evaluated for the area of the additional surface of the load relative to the cross-sectional area of the pulling means (obviously, when the first is larger; otherwise $F_v=0$). The positive sense is the one indicated in Figure 1.

Tangential forces X_f, X_s , at the road surface (Figure 1), have the expressions:

$$X_f = f \cdot Z_f; \quad X_s = f \cdot Z_s \quad (3)$$

where Z_f, Z_s are the normal reactions on the road surface, on the vertical centers of the masses of the transport platforms, N ; f - coefficient of friction between the tires and the road surface (coefficient of rolling resistance) [21]. In this way, from the equilibrium equation of forces on the horizontal is deduced:

$$F_{cr1} + F_{cr2} = F_{i1} + F_{i2} + F_{iG} + f \cdot (Z_f + Z_s) + F_v \quad (4)$$

which must be taken into account when choosing the means of towing. From case to case, the pushing means may be missing or others may be added if necessary.

Case 2. The transport system moves in a straight line, *in braking mode, on a horizontal road*. The tractor in front of the convoy works in towing mode, and the one behind the convoy works in braking mode (the sense of the inertia forces and force F_{cr2} - Figure 1 change). Taking into account the above and writing the equations of bending moments with respect to points A and B (Figure 1), in this case we obtain:

$$Z_f = \frac{G_i \cdot b + G_{pf} \cdot L_r + F_{iG} \cdot h + (F_{i1} + F_{i2}) \cdot h_{cp} + (F_{cr1} - F_{cr2}) \cdot h_c - F_v \cdot h_v}{L_r} \quad (5)$$

$$Z_s = \frac{G_i \cdot a + G_{ps} \cdot L_r - F_{iG} \cdot h - (F_{i1} + F_{i2}) \cdot h_{cp} - (F_{cr1} - F_{cr2}) \cdot h_c + F_v \cdot h_v}{L_r} \quad (6)$$

forces F_{i1} , F_{i2} , F_{iG} and F_{cr2} having contrary senses to those indicated in Figure 1. For the convoy's safety, only the rear platform wheels brake, so that:

$$X_f = \varphi_p \cdot Z_f; \quad X_s = f \cdot Z_s \quad (7)$$

where φ_p represents the grip coefficient [2]. From the equation of balance of forces along the road surface results:

$$F_{cr1} - F_{cr2} = X_f + X_s - F_{i1} - F_{i2} - F_{iG} - F_v \quad (8)$$

Note: The reduction of loads in the supports provided on the transport platforms is achieved by decreasing the speed of movement of the convoy and, therefore, the corresponding inertia forces.

Case 3. The transport system moves in a straight line, *uniformly accelerated, on a steep road under the angle* α_l . In this case, the equilibrium equations of the bending moments with respect to points A and B (Figure 1) lead to the expressions:

$$Z_f = \left[G_i \cdot (b \cdot \cos \alpha_l - h \cdot \sin \alpha_l) + G_{pf} \cdot (L_r \cdot \cos \alpha_l - h_{cp} \cdot \sin \alpha_l) - F_{iG} \cdot h - (F_{i1} + F_{i2}) \cdot h_{cp} + (F_{cr1} + F_{cr2}) \cdot h_c - F_v \cdot h_v \right] / L_r \quad (9)$$

$$Z_s = \left[G_i \cdot (a \cdot \cos \alpha_l + h \cdot \sin \alpha_l) + F_{iG} \cdot h + G_{ps} \cdot (L_r \cdot \cos \alpha_l - h_{cp} \cdot \sin \alpha_l) + F_{iG} \cdot h + (F_{i1} + F_{i2}) \cdot h_{cp} - (F_{cr1} + F_{cr2}) \cdot h_c + F_v \cdot h_v \right] / L_r \quad (10)$$

respectively,

$$F_{cr1} + F_{cr2} = F_{i1} + F_{i2} + F_{iG} + f \cdot (Z_f + Z_s) + (G_i + G_{pf} + G_{ps}) \cdot \sin \alpha_l + F_v \quad (11)$$

Case 4. The following expressions are obtained for moving the convoy *on a steep road under the angle*, α_l , *in uniform braking mode on a slope*:

$$Z_f = \left[G_i \cdot (b \cdot \cos \alpha_l + h \cdot \sin \alpha_l) + G_{pf} \cdot (L_r \cdot \cos \alpha_l - h_{cp} \cdot \sin \alpha_l) - F_{iG} \cdot h + (F_{cr1} - F_{cr2}) \cdot h_c - F_v \cdot h_v \right] / L_r \quad (12)$$

$$Z_s = \left[G_i \cdot (a \cdot \cos \alpha_l - h \cdot \sin \alpha_l) + F_{iG} \cdot h + G_{ps} \cdot (L_r \cdot \cos \alpha_l - h_{cp} \cdot \sin \alpha_l) - (F_{cr1} - F_{cr2}) \cdot h_c + F_v \cdot h_v \right] / L_r \quad (13)$$

respectively,

$$F_{cr1} - F_{cr2} = F_{i1} + F_{i2} + F_{iG} + f \cdot Z_f + \varphi_p \cdot Z_s - (G_i + G_{pf} + G_{ps}) \cdot \sin \alpha_l + F_v \quad (14)$$

considering breaking the rear platform and also the tractor coupled to it.

There are also practical situations - especially in the case of climbing slopes - when, for example, three tractor units must be used, in different combinations (all pulling and placed in front of the convoy, or two front-wheel-

drive tractors and one rear-wheel-drive, or one front-wheel-drive and two rear-wheel-drive tractors). For particularly difficult situations, more than three tractor units can be used. Combinations like the above can also be done when the convoy moves on a slope. In all these cases it is intended that the dynamic reactions, both on the trailer bogies and on the axles of the tractor units, have values as close as possible. In this way the longitudinal stability of the convoy components is fully ensured.

A very important role in the stability of the convoy's movement, in the longitudinal direction, has the **braking**. The effectiveness of a braking system is characterized by the deceleration performed by the vehicle or by the braking space, as a parameter that more eloquently reflects the correlation between the braking qualities and the safety of the movement. When determining the braking moments at the axles of the vehicle, it starts either from the condition that the braking moment does not exceed the admitted value, of grip, or from the condition that the vehicle achieves a certain maximum deceleration, imposed by the design theme (provided in the regulations). Also, when determining the braking moments at the decks it is assumed that their wheels reach the locking limit simultaneously, at a desired value of the grip coefficient. The system for oversized transport requires continuous braking, imposed by the high inertia of the loaded trailer. In this case, the tractors must be equipped with a deceleration brake. These can be: with friction, hydromechanical and with turbulent currents. When running on roads with long slopes, as mentioned above, behind the trailer is coupled a tractor that performs the constant restraint force, with long-term use.

The braking moments are calculated by multiplying the values of the normal dynamic reactions, corresponding to each axle, with the value of the sliding friction coefficient and that of the wheel radius. The choice of the distribution of braking forces on the deck is usually a compromise and is made taking into account the stability criteria of the braking vehicles. The trailer braking system must meet the following conditions: a) to be capable of certain imposed decelerations; b) to ensure the stability of the trailer during braking; c) to ensure a progressive braking, without shocks; d) to realize the correct distribution of the braking effort at the decks; e) not to require, from the driver, too much effort to operate; f) to take action quickly; g) the braking should not be influenced by the slopes of the road (due to the vertical movement of the wheels) etc. Details on the construction and calculation of braking systems are presented in [58].

2.2. Movement in curve

Figures 2 - 4 show the phases of joining the curve of a system for transporting articulated trailers. In this situation, the proper balance of each module (bogie) is considered in the joint of the articulated bolt with the transport frame. In the following it is considered that the convoy is moving along a flat, horizontal curve, without considering the influence of wind loads. In this order of ideas, the case of using two tractors is studied, one of which is pulling, the one in front of the convoy, which develops the towing force F_{cr1} , and another, the pusher, the one behind the convoy, which develops the force F_{cr2} .

Note: If the slopes or ramps are taken into account, it is necessary that the calculations of the towing forces take into account the normal expressions, set out in the previous paragraph (cases 3 and 4), to which the corresponding corrections will be made.

Case 1. The pulling module enters the curve (Figure 2). The centers of mass are considered to be at the means of the transport modules (where the pivoting supports are also located), respectively at the middle of the bridge supporting the load. The equation of the bending moment with respect to the pivot of the pulling module is presented in the form:

$$F_{cr1} \cdot L_p \cdot \sin \alpha_c - Y_1 \cdot L_p \cdot \cos \theta_m + 2 \cdot M_{p1} = 0; \quad M_{p1} = F_{cr1} \cdot l_p \cdot \sin \alpha_c \quad (15)$$

$$\theta_m = \arctan(0,5 \cdot L_p / R); \quad Y_1 = Z_{f1} \cdot \sqrt{\varphi^2 - f^2}; \quad Z_{f1} = Z_f / n_{of} \quad (16)$$

where α_c is the angle between the longitudinal axis of the pulling bogie and the direction of the tow; L_p - bogie length (platform), m ; M_{p1} - bending moment at the point A of force F_{cr1} from the end of the towel, $N \cdot m$; Y_1 - lateral guiding force of the wheels of the first deck, N ; Z_{f1} - the normal force returning to the front

axle of the towing module, taking into account its dynamics, N ; φ – grip coefficient; l_p – length of the beam, m ; n_{0f} – number of axles of the pulling module (front). From the equilibrium equation of forces along the axis of the bridge is obtained:

$$F_{cr2} = F_{i1} + F_{i2} + F_{iG} - X_f - X_s - F_{cr1} \cdot \cos \alpha_c - Y_1 \cdot \sin \theta_m$$

$$X_f = f \cdot Z_f; X_s = f \cdot Z_s \tag{17}$$

with X_f, X_s – tangential force of the front transport module decks, respectively from the rear, N ; Z_f – the normal force corresponding to the front module (including Z_{f1}), N . The other forces have the meaning presented above.

Note: For Z_f, Z_s relations (1) and (2), where a and b are replaced with $0,5 \cdot L_r$, F_{cr1} with $F_{cr1} \cdot \cos \alpha_c$, respectively $F_v = 0$.

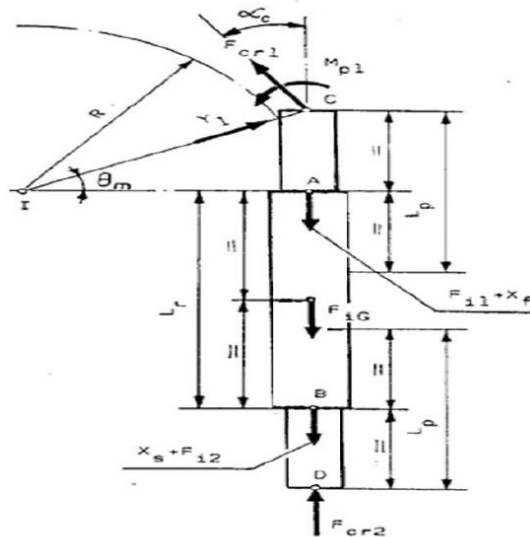

Fig. 2. System for transportation with two trailers apart from each other, with one entering the curve (sketch) [2].

Taking into account relations (15) and (17) and taking into account the annotations made, it results:

$$\{ F_{cr1}, F_{cr2} \}^{-1} = [A]^{-1} \cdot \{ B \} \tag{18}$$

where:

$$[A] = \begin{bmatrix} \left(\frac{L_p}{2} + l_p \right) \cdot \sin \alpha_c - \frac{\varphi \cdot h_c \cdot L_p}{2 \cdot n_{0f} \cdot L_r} \cdot \cos \alpha_c \cdot \cos \theta_m & - \frac{\varphi \cdot h_c \cdot L_p}{2 \cdot n_{0f} \cdot L_r} \\ \left(1 + \frac{\varphi \cdot h_c \cdot L_p}{n_{0f} \cdot L_r} \cdot \sin \theta_m \right) \cdot \cos \alpha_c & 1 + \frac{\varphi \cdot h_c \cdot L_p}{n_{0f} \cdot L_r} \cdot \sin \theta_m \end{bmatrix} \tag{19}$$

$$\{B\} = \left\{ \begin{array}{l} \frac{\varphi_p \cdot L_p}{2 \cdot n_{0f} \cdot L_r} \cdot \left[\left(\frac{G_i}{2} + G_{pf} \right) \cdot L_r - F_{iG} \cdot h - (F_{i1} + F_{i2}) \cdot h_{cp} \right] \cdot \cos \theta_m \\ \frac{\varphi_p}{n_{0f} \cdot L_r} \cdot [F_{iG} \cdot h + (F_{i1} + F_{i2}) \cdot h_{cp}] \cdot \sin \theta_m - \\ - \left(f + \frac{\varphi_p \cdot \sin \theta_m}{2 \cdot n_{0f}} \right) \cdot G_i - \left(f + \frac{\varphi_p \cdot \sin \theta_m}{n_{0f}} \right) \cdot G_{pf} - f \cdot G_{ps} \end{array} \right\} \quad (20)$$

Case 2. The pulling module entered the curve (Figure 3). Considering the angular velocity of the center of mass of the pulling module equals $\omega_m = v / R$ and its linear velocity v equals the bridge velocity (and load) it results:

$$d\theta_2 / dt = \omega_p = \omega_m + d\theta_1 / dt; \quad d\omega_p / dt = d\omega_m / dt + d^2\theta_1 / dt^2 = d^2\theta_2 / dt^2 \quad (21)$$

Considering, at the same time, the expressions of the tangential accelerations a_t and normal a_n of the elements of the convoy, entered in the curve, written in the form:

- for the front module:

$$a_{t1} = dv / dt - 0,5 \cdot L_p \cdot \omega_m^2; \quad a_{n1} = v \cdot \omega_m + 0,5 \cdot L_p \cdot (d\omega_m / dt) \quad (22)$$

- for bridge and cargo:

$$a_{tp} = dv / dt - 0,5 \cdot L_r \cdot \omega_p^2; \quad a_{np} = v \cdot \omega_p + 0,5 \cdot L_r \cdot (d\omega_p / dt) \quad (23)$$

- relations for forces and moments of inertia are obtained:

- for the front module:

$$F_{it1} = M_{m1} \cdot a_{t1}; \quad F_{in1} = M_{m1} \cdot a_{n1}; \quad M_{iz1} = I_{rm1} \cdot (d\omega_m / dt) \quad (24)$$

- for bridge and cargo:

$$F_{itp} = M_{pi} \cdot a_{tp}; \quad F_{inp} = M_{pi} \cdot a_{np}; \quad M_{izp} = I_{rp} \cdot (d\omega_p / dt) \quad (25)$$

$$\omega_p = d\theta_2 / dt = [R \cdot \omega_m \cdot \sin(\omega_m \cdot t)] / \sqrt{L_r^2 - 2 \cdot R^2 \cdot \sin^2(\omega_m \cdot t / 2)} \quad (26)$$

- for the rear module:

$$F_{it2} = M_{m2} \cdot (dv / dt); \quad F_{in2} = 0; \quad M_{iz2} = 0. \quad (27)$$

In the previous equations, with M_{m1} , M_{pi} and M_{m2} have been noted the masses of the front module, the bridge and the load and of the rear module, kg ; ω_m - the angular velocity of the front module, s^{-1} ; ω_p - the angular velocity of the bridge, s^{-1} ; F_{it1} , F_{itp} , F_{it2} - the tangential forces of inertia of the front module, the bridge and the rear module, N ; F_{in1} , F_{inp} , F_{in2} - the normal inertia forces of the front module, the

bridge and the rear module, N ; $I_{r m 1}, I_{r p}$ - moments of inertia for the front module and bridge, $k g \cdot m^2$; $M_{i z 1}, M_{i z 2}$ - turning moments relative to the vertical axes passing through the mass centers of the modules, developed by the varied movement and the masses inertia with rotating motion during the turning. $N \cdot m$; R - the average radius of the curve, m .

For angles θ_1, θ_2 and γ (Figure 3) exist the following relations:

$$\theta_1 = \gamma - \theta_2; \theta_2 = \arcsin\left\{\left[R \cdot (1 - \cos \gamma)\right] / L_r\right\}; \gamma \in \left[0; 2 \cdot \arcsin\left(0,5 \cdot L_r / R\right)\right] \quad (28)$$

The above case is considered until the pivoting support of the rear module enters the curve.

Writing the equilibrium equations of the bending moments with respect to points A and B (Figure 3) it results, following the calculations:

$$F_{c r 1} = \left[2 \cdot \left(M_{i z 1} + M_{i z 2} + M_{i z p} + M_{f 1} + M_{f 2} \right) + L_r \cdot \left(2 \cdot F_{i t 1} \cdot \sin \theta_1 + 2 \cdot F_{i n 1} \cdot \cos \theta_1 + F_{i n p} \right) + \left(L_p + 2 \cdot L_r \cdot \cos \theta_1 \right) \cdot Y_1 \cdot \cos \theta_m + \left(L_p - 2 \cdot L_r \cdot \cos \theta_1 \right) \cdot Y_2 \cdot \cos \theta_m \right] / \left[\left(L_p + 2 \cdot l_p \right) \cdot \sin \alpha_c + 2 \cdot L_r \cdot \sin \left(\alpha_c + \theta_1 \right) \right] \quad (29)$$

respectively:

$$F_{c r 2} = \left[2 \cdot \left(M_{i z 1} + M_{i z 2} + M_{i z p} + M_{f 1} + M_{f 2} \right) + 2 \cdot F_{i t 2} \cdot L_r \cdot \sin \theta_2 - F_{i n p} \cdot L_r + \left(Y_1 + Y_2 \right) \cdot L_p \cdot \cos \theta_m - F_{c r 1} \cdot \left(L_p + 2 \cdot l_p \right) \cdot \sin \alpha_c \right] / \left(2 \cdot L_r \cdot \sin \theta_2 \right) \quad (30)$$

where $F_{c r 1}$ has the expression (29). The moments of friction $M_{f 1}, M_{f 2}$ developed in the pivoting supports A and B (Figure 3), due to the modification of the angular positions of the modules - pulling (front) and pushing (back) and the platform with the transported equipment, depend on the type of construction of the respective support and the normal dynamic loads acting in the respective places.

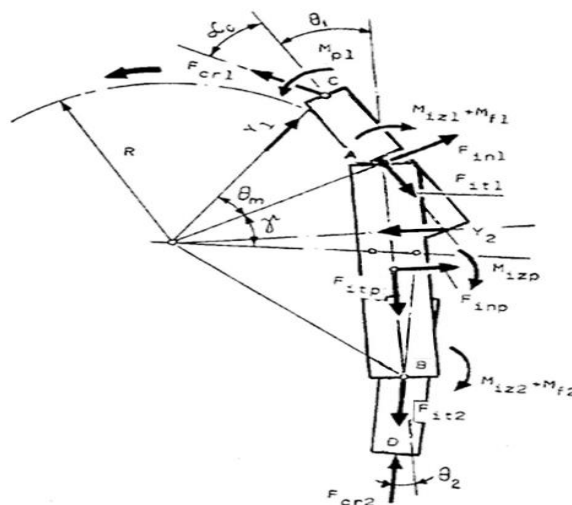

Fig. 3. System for transport with two trailers apart from each other, with one in the curve (sketch) [2].

Note: In the equations (29) and (30) the turning moments developed by the guiding forces Y_1, Y_2 were considered. Y_1, Y_2 (Figure 3), written in relation to the position of the center of mass of the front platform. A more complex calculation can be established by considering all the guiding forces characteristic of the equally loaded axles of the front platform.

Case 3. The convoy is in the curve (Figure 4). In this situation the relative position between the transport modules and the bridge is stabilized, which is why $M_{f1} = M_{f2} = 0$. From the equilibrium equations of the bending moments with respect to points A and B (Figure 4), it results:

$$\{ F_{cr1}^\bullet, F_{cr2}^\bullet \}^{-1} = [A^\bullet]^{-1} \cdot \{ B^\bullet \} \tag{31}$$

where:

$$[A^\bullet] = \begin{bmatrix} l_p \cdot \sin \alpha_c + 0,5 \cdot L_p \cdot \sin(\gamma_1 + \alpha_c) & l_p \cdot \sin \beta_c + L_r \cdot \cos \beta_c + 0,5 \cdot L_p \cdot \sin(\gamma_1 + \beta_c) \\ l_p \cdot \sin \alpha_c + L_r \cdot \cos \alpha_c + 0,5 \cdot L_p \cdot \sin(\gamma_1 + \alpha_c) & l_p \cdot \sin \beta_c + 0,5 \cdot L_p \cdot \sin(\gamma_1 + \beta_c) \end{bmatrix} \tag{32}$$

$$\{ B^\bullet \} = \begin{Bmatrix} -M_{iz1} - M_{iz2} - M_{izp} + 0,5(Y_1 + Y_2) \cdot L_p \cdot \cos \theta_m - 0,5 \cdot F_{inp} \cdot L_r + (Y_3 + Y_4) \cdot (0,5 \cdot L_p \cdot \cos \theta_m - L_r \cdot \sin \gamma_1 \cdot \sin \theta_m) + F_{it2} \cdot L_r \cdot \sin \gamma_1 - F_{in2} \cdot L_r \cdot \cos \gamma_1 + (Y_3 - Y_4) \cdot L_r \cdot \cos \gamma_1 \cdot \cos \theta_m \\ -M_{iz1} - M_{iz2} - M_{izp} + 0,5 \cdot (Y_3 + Y_4) \cdot L_p \cdot \cos \theta_m + 0,5 \cdot F_{inp} \cdot L_r - (Y_1 + Y_2) \cdot (L_r \cdot \sin \gamma_1 \cdot \sin \theta_m - 0,5 \cdot L_p \cdot \cos \theta_m) + F_{it2} \cdot L_r \cdot \sin \gamma_1 + F_{in2} \cdot L_r \cdot \cos \gamma_1 + (Y_1 - Y_2) \cdot L_r \cdot \cos \gamma_1 \cdot \cos \theta_m \end{Bmatrix} \tag{33}$$

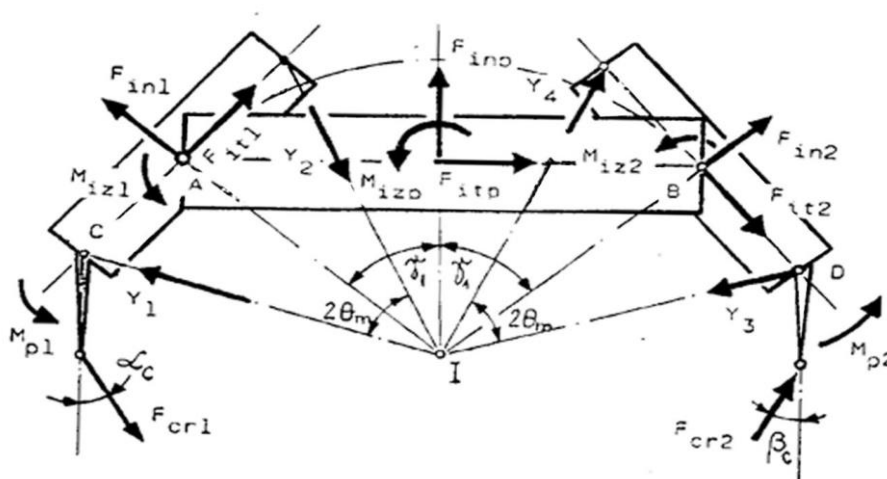

Fig. 4. System for transportation with two trailers apart from each other, in the curve (sketch) [2].

Note: The above problem is treated in the same way when the pulling module is out of the curve, the rear one being in the corner. The loads intervening has explanations as before.

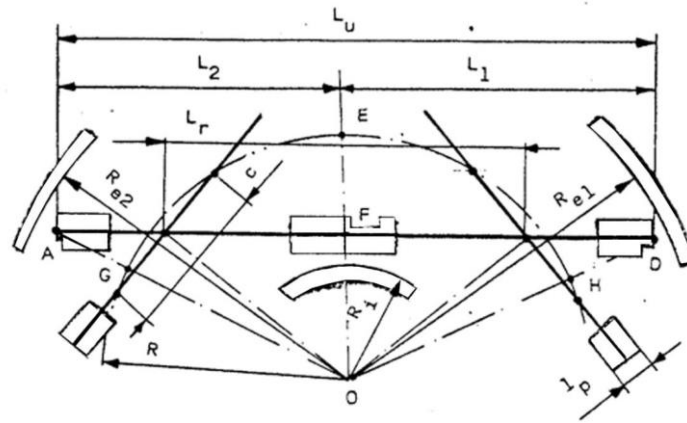

Fig. 5. At the study of entering and exiting the curves for a transported equipment on two platform apart from each other (sketch)

3. THE GEOMETRY OF JOINING THE CURVE OF TWO PLATFORMS APART FROM EACHOTHER

Considering the results obtained previously, with data from Figure 5, it results the following expression for the theoretical entering to the center of the curve, *O*:

$$EF = R \cdot \left[1 - \sqrt{1 - \frac{c^2}{(4 \cdot R^2)} - \frac{L_r^2}{(4 \cdot R^2)}} \right] \tag{34}$$

respectively, for the real one:

$$EF^* = EF + 0,5 \cdot D_u \tag{35}$$

where *D_u* means the maximum outer diameter of the transported equipment (of the characteristic arrangements), *m*; *R* – mean radius of curve, *m*; *c* – the distance between the centers of the platforms (considered identical) on the average circumference of the curve, *m*; *L_r* – the distance between the pivoting supports, *m*.

The inner radius of the curve will have to meet the condition:

$$R_i = R - EF^* - \Delta R_i \tag{36}$$

while the outer radius is given by the expression:

$$R_e \geq \max \{ R_{e1}; R_{e2} \} \tag{37}$$

where:

$$R_{e1} = R + HD^* + \Delta R_e; \quad R_{e2} = R + AG^* + \Delta R_e \tag{38}$$

where:

$$HD^* = R \cdot \left[\sqrt{1 + \frac{(4 \cdot L_1 - c^2 - L_r^2)}{(4 \cdot R^2)}} - 1 \right] + 0,5 \cdot D_u \tag{39}$$

$$AG^* = R \cdot \left[\sqrt{1 + \frac{(4 \cdot L_2 - c^2 - L_r^2)}{(4 \cdot R^2)}} - 1 \right] + 0,5 \cdot D_u \tag{40}$$

the geometric dimensions shown in figure 5 representing: L_1, L_2 – distances from the center of mass of the equipment to its ends, m ; L_u – the maximum length of the load, m . It is easy to see that the width of the road on which the analyzed convoy can travel must be greater than the difference ($R_e - R_i$).

4. CONCLUSIONS

The full safety in operating equipment of the process industries, in general, of high complexity and oversized, with large masses, in particular, is dependent on the compliance with the normed conditions, on the behavior of the working parameters, chemical and / or mechanically aggressive substances, working at low or high pressures and also at negative or high temperatures. An essential role in the chain of characteristic activities has the design (choosing the appropriate construction materials, but to be technically and economically competitive, the influence of the founding ground, the tectonic behavior, meteorological loads), the fabrication, the transport, the assembly and the stable operation. In order to preserve the geometrical characteristics of the transported equipment, a careful analysis of the stages of their movement is required, starting with the proper fixing of them on platforms [4–7] and continuing with longitudinal and transverse stability, on roads with reduced inclinations [14–26]. Following this idea, the present study studies the calculation of the towing forces of a convoy for transport with two platforms apart from each other, of an oversized mechanical equipment, in a straight line or in curves. It is also offered, the means of appreciation of the geometry of the route in curves, in the case expressed above.

The specified methodologies can be developed in future research, considering higher road slopes and more aggressive weather conditions. At the same time, the situations in which the entrances and exits of the transport platforms must be evaluated, respectively the trajectories along which the towing vehicles move, can be analyzed.

REFERENCES

- [1] Iatan, I.R., SARbu, L., Transportarea și montarea utilajelor industriilor de proces (partea I), Institutul Politehnic Bucuresti, Bucuresti, 1991.
- [2] Iatan, I.R., Vasilescu, I., Transportarea utilajelor tehnologice agabaritice, Editura Matrix Rom, Bucuresti, 2002.
- [3] Importanța transportului în economie, Editura Fundației România de Măine, cap. 1., București, 2013.
- [4] Iatan, I.R., Alamoreanu, E., Chirita, R., Optimizarea constructiva si pozitionala a urechilor simetrice simple pentru ancorarea utilajelor transportate, Buletinul Universitatii Petrol – Gaze din Ploiesti, vol. XLVII – L, no. 8, 1998, p. 153 – 158.
- [5] Iatan, I.R., Alamoreanu, Elenea, Chirita, R., Elemente de calcul al carligelor de ridicare de tip “Gama”, Buletinul Universitatii Petrol – Gaze din Ploiesti, vol. XLVII – L, no. 8, 1998, p. 159 – 164.
- [6] Iatan, I.R., Aspecte privind rezemarea echipamentelor pe platforme de transport, Constructia de masini, vol. 54, no. 1-2, 2002, p. 9 -12.
- [7] Iatan, I.R., Popa, T.C., Dobra, S.G., Dumitrescu, V., Unele aspecte de calcul al butonilor pentru ridicarea utilajelor tehnologice, Buletinul Universitatii Petrol-Gaze din Ploiesti, vol. LIV, seria Tehnica, no. 3, 2002, p. 105 –114.
- [8] Mainskov, N.V., Gluskov, V.S., Savalov, M.L., Skvortov, V.I., Azabov, I.O., Rasciet i proektirovanie proșin, Samara, Minobranauki Rosii, 2011.
- [9] Semakina, K.O., Montaj, eksploatația i remont oborudovaniia otrasli, Izd. Tomskogo Politehniceskogo Universiteta, Tomsk, Rossiia Federația, 2015.
- [10] Iatan, I.R., Salca, C., Stătescu, M., Some aspects regarding the loading of technological industrial equipment on transportation platforms, Buletinul Universitatii Petrol – Gaze din Ploiesti, vol. LXVIII, no. 4, 2016, p. 1 – 7.
- [11] Legea nr.198/09.07.2015, publicată în M. O. nr. 237/16.07.2015, privind regimul drumurilor. Norme privind autorizarea si desfasurarea circulatiei vehiculelor rutiere cu mase si/sau cu dimensiuni ce depasesc masele si/ sau dimensiunile maxime admise prevazute în Ordonanta Guvernului nr. 43/1997 privind regimul drumurilor, republicata, cu modificarile si completarile ulterioare.
- [12] OUG nr. 43/1997, Norme privind autorizarea si desfasurarea circulatiei vehiculelor rutiere cu mase si/sau dimensiuni ce depasesc masele si/sau dimensiunile maxime admise (modificari si completari ulterioare).
- [13] Danil, F., Organization of the delivery of oversized cargo, Bachelor's Thesis, South – Eastern Finland, University of Applied Sciences, April, 2017.
- [14] Penișin, V.N., Organizația transportnăh uslug i bezopasnosti transportnogo proțessa, Izd. FGBOY VPO “TGTU”, Tambov, Federația Rusa, 2014.

- [15] Fistung, D.F., Transporturile rutiere din România, Academia Română, Institutul National de Cercetari Economice “Costin C. Kiritescu”, Centrul de Informare si Documentare Economica, Bucuresti, 2019.
- [16] Budzik, A., Budzik, T., External effect of transport activities on the example of Poland and the European Union, Proceedings of 23rd International Scientific Conference. Transport Means, Kaunas University of Technology, Lithuania, 2019, p. 566 – 573
- [17] Code of practice – Safety of loads on vehicles (third edition), Department for Transport, TSO, London, 2002.
- [18] Hodivoianu, D., Sfaturi utile pentru transportul agabaritic, Trans. Info, 2017.
- [19] Ciont, N., Contributii la realizarea unui sistem de monitorizare a drumurilor, Teza de doctorat, Universitatea Tehnica din Cluj-Napoca, 2015.
- [20] Florea, C., Suport de curs pentru pregatirea și perfectionarea conducatorilor auto care efectueaza transport rutier marfa cu autovehicule a caror masa maxima autorizata este mai mare de 3,5 tone, Universitatea din Pitesti, 2016.
- [21] <https://gruzovichkof.ru/poleznaja-informacija/negabaritnyj-gruz> (15.03.2020).
- [22] https://ec.europa.eu/transport/road_safety/sites/roadsafety/files/vehicles/doc/abnormal_transport_guidelines_fr.pdf, (15.03.2020).
- [23] Hanji, J., Transport of oversized in the Czech Republic – Critical places on the route from the perspective of road infrastructure and traffic safety, Proceedings of 23rd International Scientific Conference. Transport Means, Kaunas University of Technology, Lithuania, 2019, p. 615 - 620.
- [24] Macioszek, E., Conditions of oversize cargo transport, Scientific Journal of Silesian University of Technology. Series transport Katowice, Poland, vol. 102, 2029, p. 109-117.
- [25] Petraska, A., Čižiūniene, K., Prentkovskis, O., Jarašūnienė, A., Methodology of selection of heavy and oversized freight transportation system, Transport and Telecommunication, vol. 19, no. 1, 2018, p. 45 - 48.
- [26] Duguay, J., Intégration de l'analyse du cycle de vie dans la gestion d'une flotte de véhicules, Université Laval, Québec, Canada, 2017.
- [27] Rotaru, I., Transporturi, expediții și asigurări de mărfuri și călători (ediția a IV – a), Editura ALMA MATER, Sibiu, 2007.
- [28] Palko, G.K., Lemmen, S.D., Risques climatiques et pratiques en matière d'adaptation pour le secteur canadien des transports 2016, Gouvernement du Canada, 2017.
- [29] Transporturi specializate. Transport agabaritic, http://www.artri.net/transport-agabaritic-informatii-generale_43.html (15.03.2020).
- [30] <https://www.iproctiamuncii.ro/norme-protectia-muncii/nssm-23> (15.03.2020).
- [31] Nistor, N., Vasiliu, C., Teoria traficului rutier si siguranta circulatiei, Litografia Institutului Politehnic din Bucuresti, 1977.
- [32] Cadar, Gh., Remorci si semiremorci auto, Editura Tehnica, Bucuresti, 1965.
- [33] Cuncev, I., Revista cailor ferate romane, 39, no. 2, 1993, p. 7 – 9.
- [34] Iatan, I.R., Dumitrescu, V., Longitudinal stability of platforms for the transportation of technological no gauge equipments (I), Modelling and Optimization in the Machines Building Field, Romanian Academy, Branch Office of Iași, MOCM, vol. 8, 2002, p. 78 – 84.
- [35] Iatan, I.R., Dumitrescu, V., Longitudinal stability of platforms for the transportation of technological no gauge equipments (II), Modelling and Optimization in the Machines Building Field, Technical Sciences Academy of Romania, University of Bacau, MOCM, 2003, vol. 1, p. 47 – 51.
- [36] Iatan, I.R., Dumitrescu, V., Stabilitatea longitudinală a platformelor pentru transportarea utilajelor tehnologice agabaritice (III), Buletinul științific al celei de a XXVIII-a Conferința Natională de Mecanica Solidelor, Secțiunea 4, Universitatea Valahia din Targoviste, 28 – 29 mai 2004, p. 60 – 64.
- [37] Iatan, I.R., Stabilitatea longitudinală a platformelor pentru transportarea utilajelor tehnologice agabaritice (IV), Buletinul științific al celei de a XXVIII-a Conferința Natională de Mecanica Solidelor, Secțiunea 4, Universitatea Valahia din Targoviste, 28 – 29 mai 2004, p. 65 – 69.
- [38] Iatan, I.R., Salca, C., Stasescu, M., Stabilitatea miscarii longitudinale a platformelor tip 4 x 4 pentru transportarea echipamentelor tehnologice agabaritice, Sinteze de Mecanică Teoretică și Aplicată, vol. 7, no. 1, 2016, p. 51 – 62.
- [39] Iatan, I.R., Stasescu, M., Salca, C., The stability of longitudinal movement during the transportation of industrial oversized equipment on a platform with an even number of axles. General case, The Scientific Bulletin of VALAHIA University MATERIALS and MECHANICS, vol. 15, no. 12, 2017, p. 43 – 47.
- [40] Stasescu, M., Iatan, I.R., Durbaca, I., Enachescu, G.L., Aspecte privind siguranta transportarii echipamentelor industriale agabaritice. Stabilitatea miscarii longitudinale a mijloacelor pentru tractare rutiera, Sinteze de Mecanica Teoretică și Aplicată, vol. 10, no. 4, 2019, p. 231 – 246.

- [41] Statescu, M., Iatan, I.R., Durbaca, I., Enachescu, G.L., Aspecte privind siguranta transportarii echipamentelor industriale agabaritice. Stabilitatea miscarii longitudinale a mijloacelor pentru tractare rutiera, Sinteze de Mecanica Teoretica si Aplicata, vol. 10, no. 4, 2019, p. 231 – 246.
- [42] Iatan, I.R., Stabilitatea transversala a miscarii recipientelor – cisterne rutiere sau feroviare pentru transportul GPL, Info GPL, no. 20, 2007, p. 11 – 14.
- [43] Iatan, I.R., Sima, T., Stabilitatea transversala a platformelor pentru transportarea utilajelor tehnologice agabaritice (I), Constructia de masini, vol. 55, no. 4, 2003, p. 53 – 56.
- [44] Iatan, I.R., Sima, T., Stabilitatea transversala a platformelor pentru transportarea utilajelor tehnologice agabaritice (II), Constructia de masini, vol. 55, no. 5, 2003, p. 53 – 60.
- [45] Iatan, I.R., Sima, T., Stabilitatea transversala a platformelor pentru transportarea utilajelor tehnologice agabaritice (III), Constructia de masini, vol. 55, no. 7 - 8, 2003, p. 34 – 38.
- [46] Iatan, I.R., The transversal stability of the platforms for the transportation of the great technological equipment (IV), Modelling and Optimization in the Machines Building Field, MOCM, University of Bacau, vol. 1, 2004, p. 62 – 67.
- [47] Iatan, I.R., The transversal stability of the platforms for the transportation of the great technological equipment (V), Modelling and Optimization in the Machines Building Field, MOCM, University of Bacau, vol. 1, 2004, p. 68 – 72.
- [48] Statescu, M., Iatan, I.R., Durbaca, I., Enachescu, G.L., Aspecte privind siguranta transportarii echipamentelor industriale agabaritice. Stabilitatea transversala a miscarii vehiculelor pentru transportare și a platformelor încărcate, Sinteze de Mecanica Teoretica și Aplicata (in print).
- [49] Tecusan, N., Nitescu, Gh., Tractoare și automobile, Editura Didactica si Pedagogica, Bucuresti, 1977.
- [50] Poenaru, M., Exploatarea autovehiculelor, Editura Didactica și Pedagogica, Bucuresti, 1974.
- [51] Ghiulai, C., Vasiliu, Ch., Dinamica autovehiculelor, Editura Didactica si Pedagogica, Bucuresti, 1975.
- [52] http://www.autovehicule-rutiere.ro/wp-content/uploads/cursuri/dinamica_autovehiculelor/Dinamica_autovehiculelor_Cap-1-6.pdf (15.03.2020).
- [53] <http://publications.lib.chalmers.se/records/fulltext/244369/244369.pdf> (15.03.2020).
- [54] <http://mehanizacija.ftn.uns.ac.rs/wp-content/uploads/2017/07/Part-12.pdf> (15.03.2020).
- [55] Rajamani, R., Vehicles dynamics and control, Springer, Mechanical Engineering Series, 2006.
- [56] Lechner, D., Analyse du comportement dynamique des vehicules routiers legers developpement d'une methologie appliquee à la securité primaire, Thesis, École Centrale de Lyon, France, 2002.
- [57] Sarbu, L., Legendi, A., Utilaje si masini de tractiune si transport pentru constructii, operatiuni miniere si drumuri. Constructie, elemente de calcul, vol. 1, 2, Editura Matrix Rom, București, 2014.
- [58] Fratila, Gh., Marculescu, Gh., Sistemele de franare ale autovehiculelor, Editura Tehnica, Bucuresti, 1986.
- [59] Rehnberg, A., Suspension design for off-road constructions machines, Thesis, Royal Institute of Technology, Stockholm, Sweden, 2011.